

# Mobile Application for Bus Ticket Booking Effectiveness

Alfia Candra Kusumapradiwi  
Yogyakarta University of Technology  
Yogyakarta, Indonesia

Anita Fira Waluyo  
Yogyakarta University of Technology  
Yogyakarta, Indonesia

## ABSTRACT

The development of information technology is growing so rapidly that it affects all aspects of life. The rapid progress of technology has exerted a profound impact on the ever-expanding tourism industry [1]. In the midst of the rapid development of science and technology, many bus tickets are still booked manually, this method is less effective and efficient. Therefore, in order to mitigate such drawbacks, this study improves upon the previous reservation method by introducing scheduling through the system [2]. In fact, the adoption of these systems, together with a good implementation strategy, enhances the strengths of a business, while mitigating its weaknesses [3]. The goal is to build an effective online-based ticket booking application. The system is expected to solve the problems that occur and can increase effectiveness and efficiency so that services will be better than the existing system. So that services will be better than the existing system.

## General Terms

Android, Flutter, Laravel, Ticket Booking, Bus

## Keywords

Booking Application, Bus Ticket, Business, Effectiveness

## 1. INTRODUCTION

In today's world, we are faced with various uncertainties, such as pandemics and epidemics, regional military conflicts, climate change-related disasters, the global financial crisis, and other unexpected events, which make decision-making challenging. The transportation industry, being a service industry, is particularly vulnerable to dynamic uncertainties from both the demand and the cost sides [4]. There are many aspects that are problematic due to poor system performance. By examining this data, travel companies can enhance their ability to deliver customized and pertinent products and services to their customers, ensuring a more personalized and fitting experience for each individual [5].

The competition factor in attracting customers is also getting tougher, especially for transportation service providers. Some transportation service providers have utilized the internet as a medium to introduce and improve their services to customers. The high level of popularity of social internet services has led to new threats to national security due to information operations in the information space of services [6]. So this research will utilize the role of the internet to facilitate bus ticket booking to be more effective.

This system was created with the dart and PHP programming languages and the flutter and laravel frameworks. all data regarding ticket bookings will be stored through a database managed by MySQL. Their performance is compared using a common CRUD operations [7]. User data and admin data can be connected to the API (application programming interface). API recommendations greatly alleviate the selection burdens of enterprises in identifying potential useful APIs to meet their

business demands [8]. Therefore, this research attempts to reconfigure how consumers perceive information disclosure, while their personal information can also be used safely and effectively [9].

## 2. RESEARCH METHOD

The development of component-based systems and service oriented systems is currently an important area in software engineering [10]. As the number and complexity of software to automate systems is increasing, software engineering in this domain is becoming increasingly important [11]. The system designed is an android-based bus ticket booking system so that customers can book bus tickets online. This system can also provide bus schedules that are still available up to date.

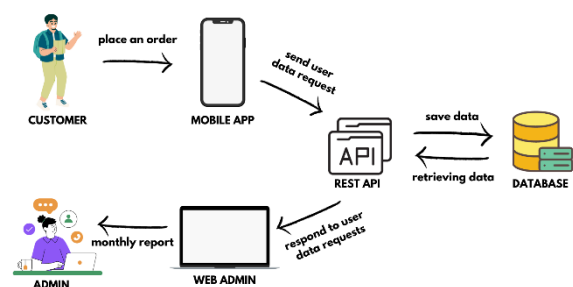

Fig. 1 Architecture Diagram

Based on the architecture diagram above, it can be seen that customers who act as users can place orders through the mobile application. Meanwhile, the admin will receive monthly reports through the admin website. Customer data will be sent to the database via Rest API, and then will be sent to the admin via the website. The emergence of web application programming interfaces (referred to as APIs hereafter) defines a new way of making applications easier to develop, driving innovations of new technology with limited resources [12].

### 2.1 Data Collection Procedure

Collecting and organizing data to understand and answer real-world questions is an increasingly important skill in our current world [13]. The data collection procedure was carried out using 3 stages namely the direct observation or observation stage, the interview stage and the literature study stage.

#### 2.1.1 Direct Observation (Observation)

Data collection is done by direct observation directly at the Yani Transportation Company which is located at Dongkelan, Panggungharjo, Sewon, Bantul. Observation Observation is carried out by observing order transaction activities, booking transactions, recording bookings, and the payment and report generation process that takes place at PO Yani Transport.

### 2.1.2 Interview

Data collection was carried out through interviews with Mrs. Yani as the owner of PO. Yani Transport directly, the things that were asked. The things that were asked or the contents of the interview were about the bus ticket booking process, the payment process, the report generation process, and the report generation process and the transaction process carried out by PO. Yani Transport so far. This interview provides results so that researchers understand what is needed by the company about the system to be created.

### 2.1.3 Literature Study

Literature study is a method of collecting data by studying and recording written document data from books and journals related to the research to obtain the theoretical basis of the data needed.

## 2.2 System Design Logic

The system design uses Data Flow Diagram (DFD) as a data flow method and ERD (Entity Relationship Diagram) as data modeling. DFD has been constructed using [open-source software tools that provide users with different shapes and environments [14]. The data design process uses a Data Flow Diagram (DFD) which is divided into context diagrams, DFD level 1 and DFD level 2.

### 2.2.1 Context Diagram

Context diagram is a diagram that consists of one process and describes the scope of a system. This system is used by the admin who will manage all master data and can view booking reports from the system. Users can make ticket reservations and make payment processes.

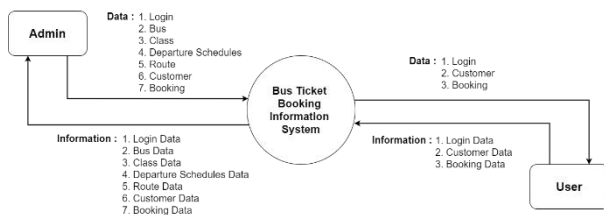

Fig. 2 Context Diagram

### 2.2.2 Level Diagram

A level diagram is a diagram that illustrates the overall process functions in the system in stages. Level diagrams are used to prepare for drawing data flow diagrams (DFDs) to lower levels. Even lower levels. In the level diagram there are logins, master data, transaction data, and reports. In the level diagram there are login, master data, transaction data, and reports. In the master data there are bus, schedule, route, and class data. In the transaction data there is booking data and payment data. In the report there is a financial report for the admin.

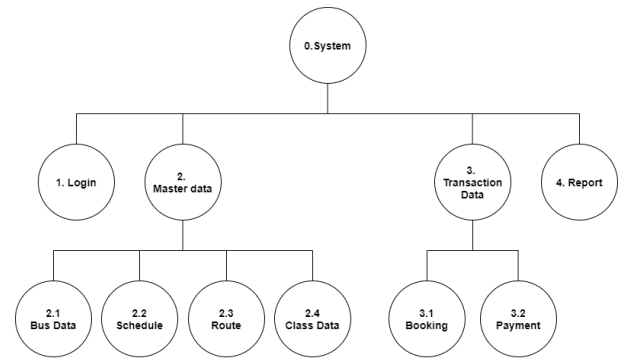

Fig. 3 Level Diagram

### 2.2.3 Data Flow Diagram (DFD)

This DFD (Data Flow Diagram) will explain the login process which has two access rights, namely admin and user. The login process has two access rights, namely admin and user. The process of adding login data, bus data, schedule data, route data, class data, user data and managing bookings is carried out by the admin. The process carried out by the user is the process of booking tickets, logging in as a user and making payments with a payment code that has been determined by the system. Existing confidentiality analyses on DFDs support either information flow control or access control, which are the most common confidentiality mechanisms [15].

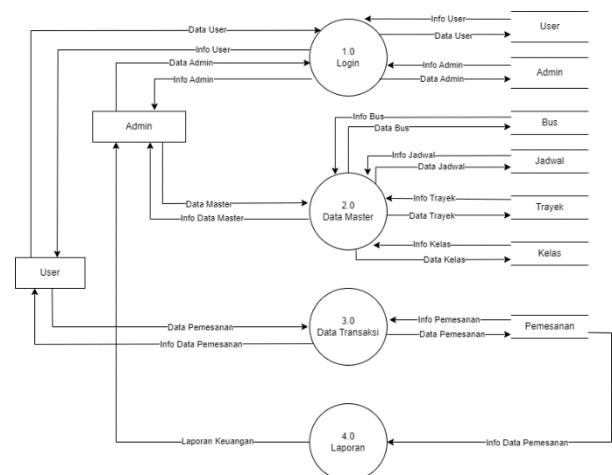

Fig. 4 Data Flow Diagram

### 2.2.4 Entity Relationship Diagram (ERD)

Entity Relationship Diagram (ERD) is a diagram used to design a database that is used to show the relationship between visible entities or objects and their attributes. This information is invaluable for designing top-down approaches where algorithms are used to determine what scenarios give better results [16].

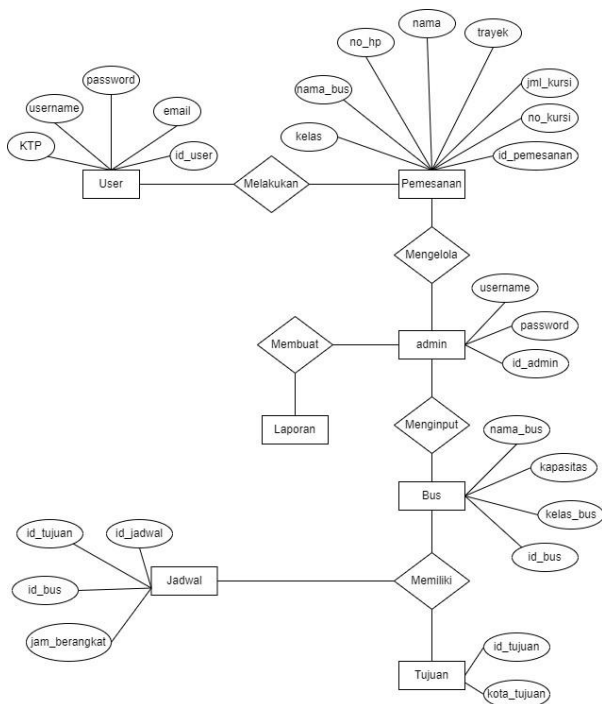

Fig. 4 Entity Relationship Diagram

### 2.2.5 Table Relation

Relationships between tables are depicted with lines connecting between each table.

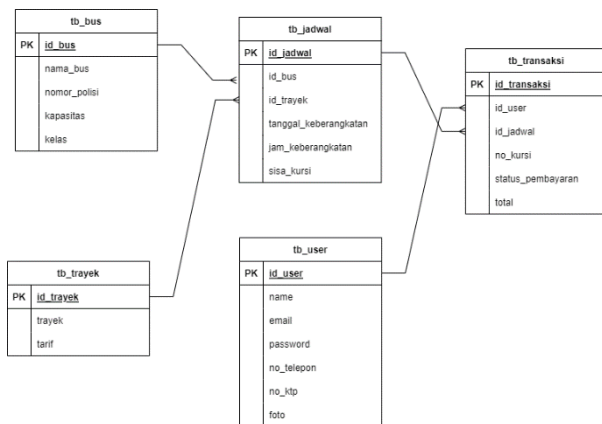

Fig. 5 Table Relation

## 2.3 Physical Design

Interface design is the communication mechanism between the user and the system. The interface can receive information from the user and provide information to the user to help the search flow.

### 2.3.1 Admin Login Page

This login page is the initial page when the admin enters the home page to manage the data that will be added to the order. Admins must have an email and password first to be able to enter the home page.

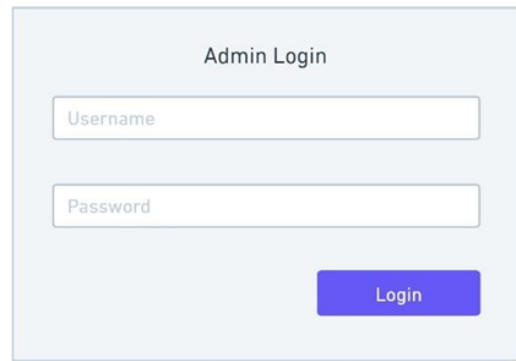

Fig. 6 Admin Login Page

### 2.3.2 Home Page

The home page is the first page after the admin can log in. The admin home page can manage the data in it such as bus data, schedule data and destination data.

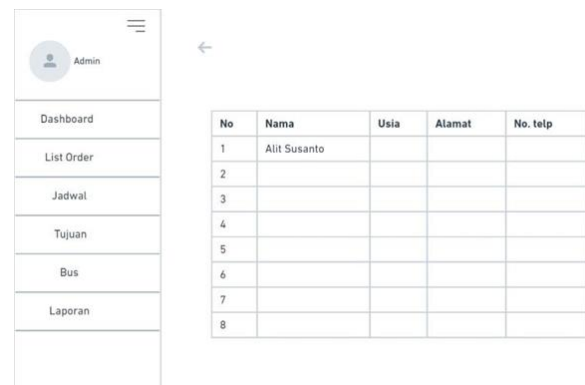

Fig. 7 Home Page

### 2.3.3 Order List Page

On this page there is a display when the admin wants to check the list of orders that have been placed by users

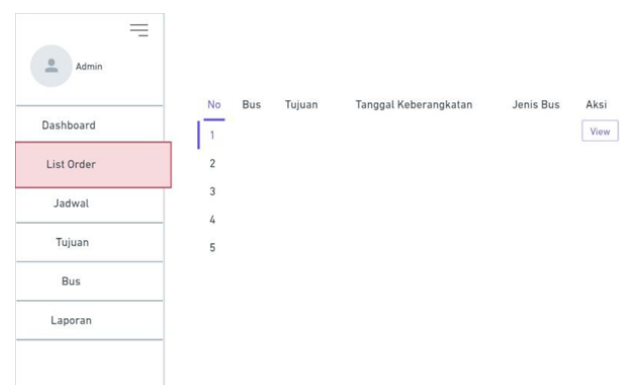

Fig. 8 Order List Page

### 2.3.4 User Sign In Page & Ticket Search Page

This sign in page is for users to register or create an account before entering the home page to search for the required tickets. Users first create an account in order to enter the next page. And this ticket search page is only for users who want to book tickets. This page contains the date to be selected for the user's

departure, origin city, destination city and how many seats are needed.

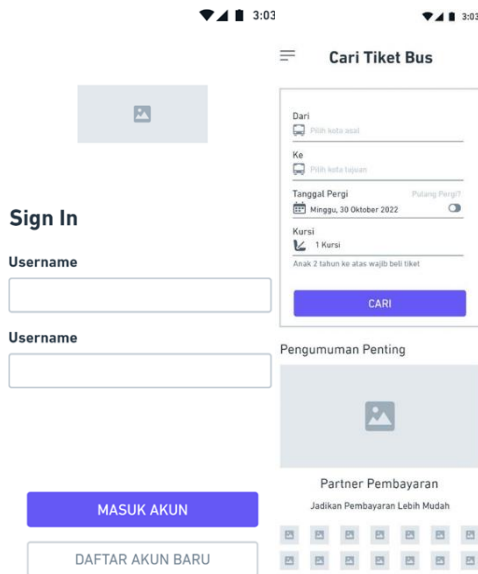

Fig. 9 User Signin & Ticket Search Page

### 2.3.5 Class Selection Page & Seat Selection Page

This page contains classes and their prices. Users can choose a class according to their needs. This seat selection page can be used by users to select seats that are still available.

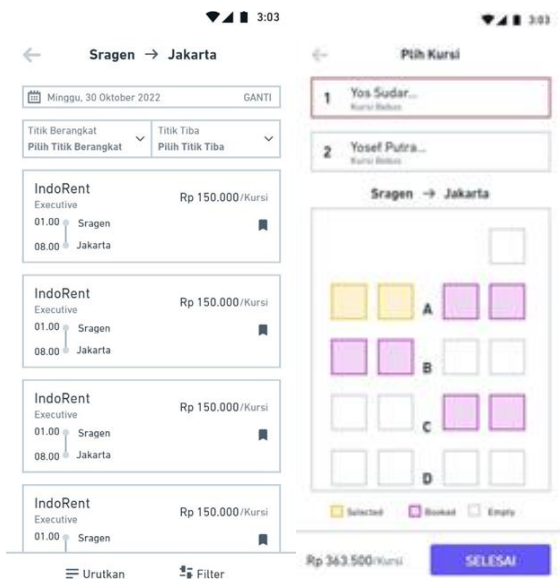

Fig. 10 Class Selection Page & Ticket Search Page

### 2.3.6 Order Page

This page is used by users when they have placed an order and will make a payment.

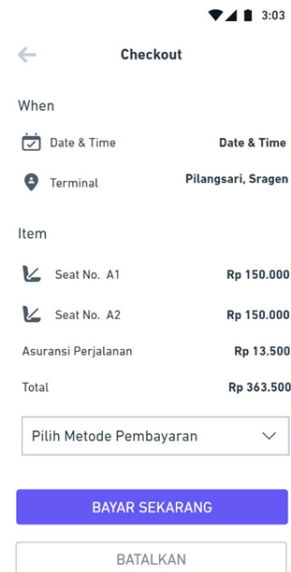

Fig. 11 Order Page

## 3. RESULT AND DISCUSSION

### 3.1 Assumption

The app can be used by both users and admins. users use the mobile app while admins use the website.

### 3.2 Hypothesis

This hypothesis is based on assumptions obtained and proven in the research stage. The hypothesis of this research is "Mobile Application for Bus Ticket Booking Effectiveness".

### 3.3 Run an Experiment

In the implementation of this application design where the android application is designed using the Flutter framework while the website is designed using the PHP programming language. The database used in this application is MySQL. MySQL Cluster is a widely used clustered database used to store and manipulate data which has a shared-nothing clustering for the MySql database management system providing high availability and high throughput with low latency [17]

#### 3.3.1 Login Admin Page

The login page is the process to enter the online service to go to the next page. On the login page there is email and password input.

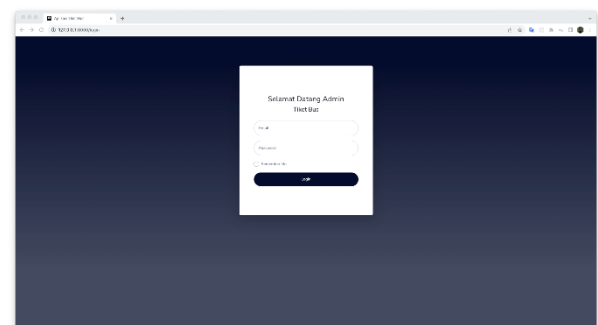

Fig. 12 Login Admin Page

### 3.3.2 Admin Dashboard Page

This dashboard page is a page after the admin has successfully logged in. On this page the admin can process data for bus scheduling for customers.

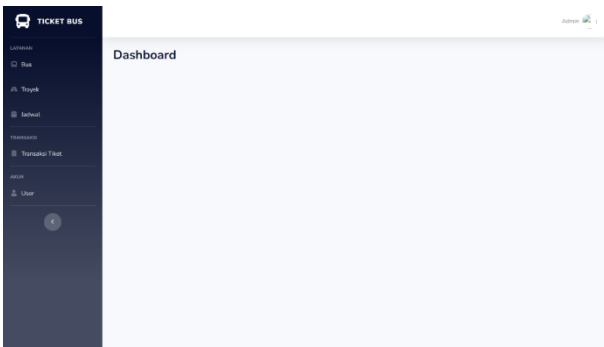

Fig. 13 Admin Dashboard Page

### 3.3.3 Bus List Page

The bus list page can be managed by the admin. This page is used to enter the bus name, police number, capacity and bus class.

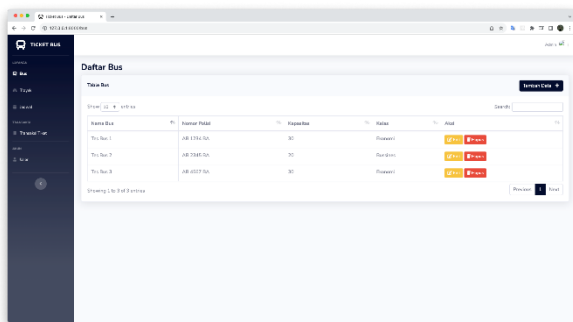

Fig. 14 Bus List Page

### 3.3.4 Route List Page

This route list page can only be managed by the admin. On this page there are routes and fares.

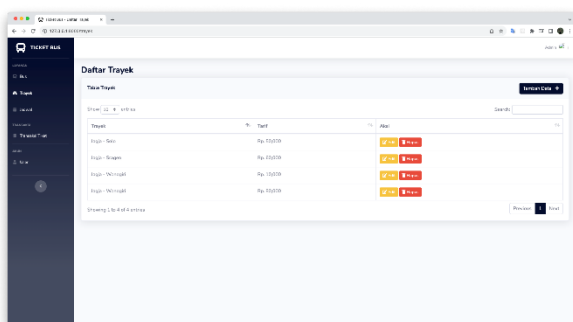

Fig. 15 Route List Page

### 3.3.5 Schedule List Page

The bus schedule list page can be managed by the admin. This page can add bus names and routes that have been inputted as well as the date and time of departure.

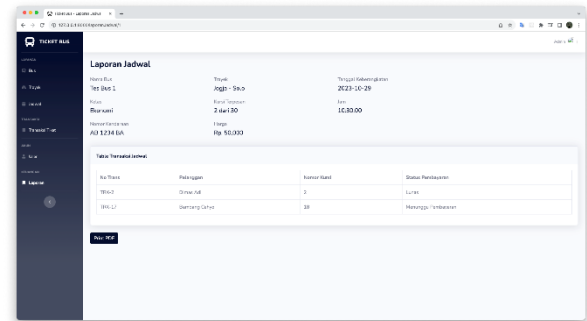
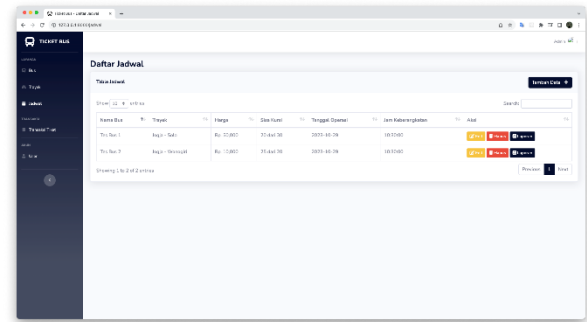

Fig. 16 Schedule List Page

### 3.3.6 Transaction List Page

This transaction list page is a page to display order data that has been made by customers. On this page the admin can change the payment status. This page contains the transaction number, customer name, bus name, route, seat number, departure time, date and payment status.

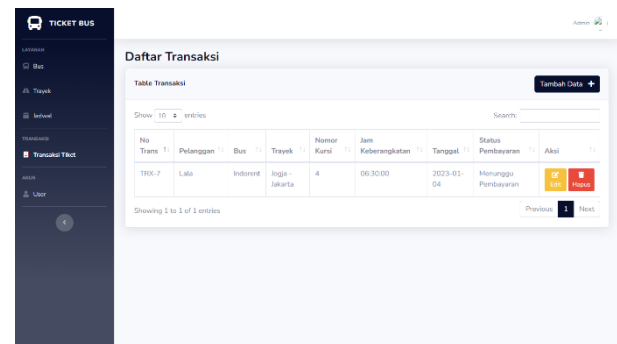

Fig. 17 Transaction List Page

### 3.3.7 User List Page

On this page the admin can see users who have registered. This user list contains name, email, ID number, phone number, and access rights.



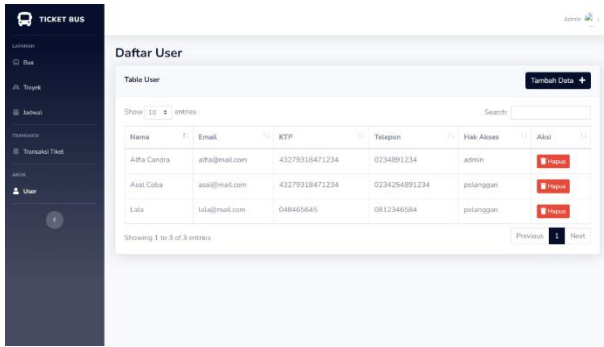

Fig. 18 User List Page

### 3.3.8 Financial Statement Page

This page contains a report on bus ticket sales at PO Yani Transport. On this page the admin can view and print the report. There is a print button that is used to print the report in the form of a downloadable PDF.

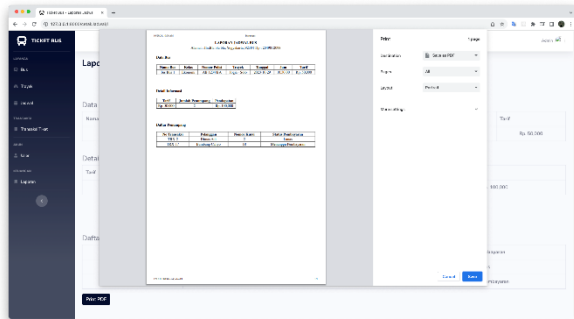

Fig. 19 Financial Statement Page

### 3.3.9 Customer Login Page and Registration Page

On this login page, customers who already have an account can enter the registered email and password. If you do not have an account, you can register first by pressing the register button. On this page, users who do not have an account can register first by entering email, password, full name, telephone number and ID card number.

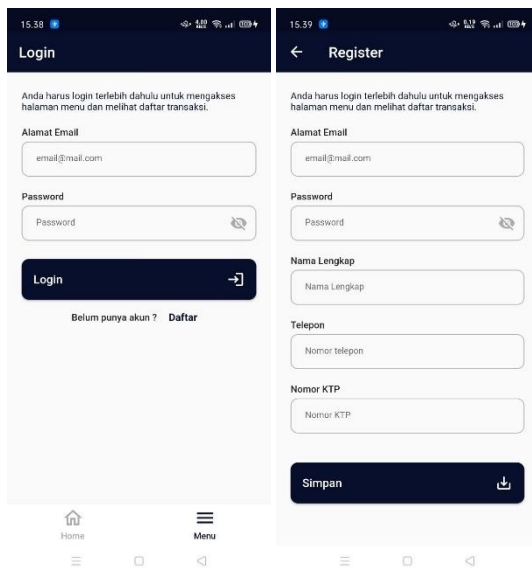

Fig. 20 Customer Login Page & Registration Page

### 3.3.10 Customer Home Page & Schedule Search Page

On this page users can search for tickets by entering the desired departure location, destination, and date. On this page customers can select the desired bus with the class and price that is still available.

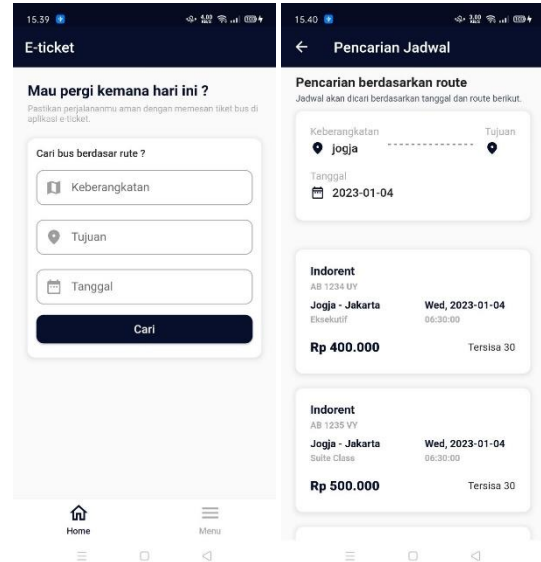

Fig. 21 Customer Home Page & Schedule Search Page

### 3.3.11 Seat Select Page Display & Ordering Page Display

On this page, customers can select seats that are still available. After selecting a seat, customers can place an order. On this page customers can see the results of orders that have been made.

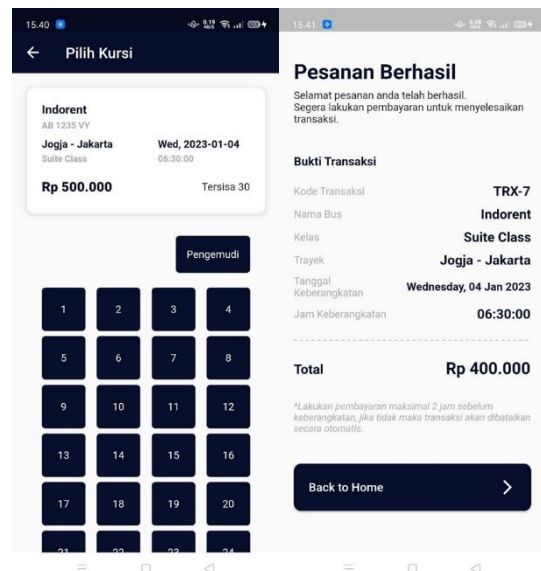

Fig. 22 Seat Select Page Display & Ordering Page Display

### 3.3.12 Payment Page view

On this menu page, customers can make the desired payment selection, namely by transfer or cash method.

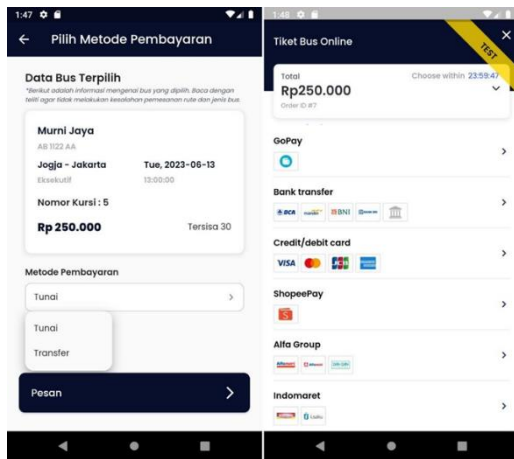

Fig. 23 Payment Page View

### 3.3.13 Menu Page & Profile Page

On this menu page, customers can change personal data and view a list of transactions and exit the account. On this page users can change their personal data and change their profile picture.

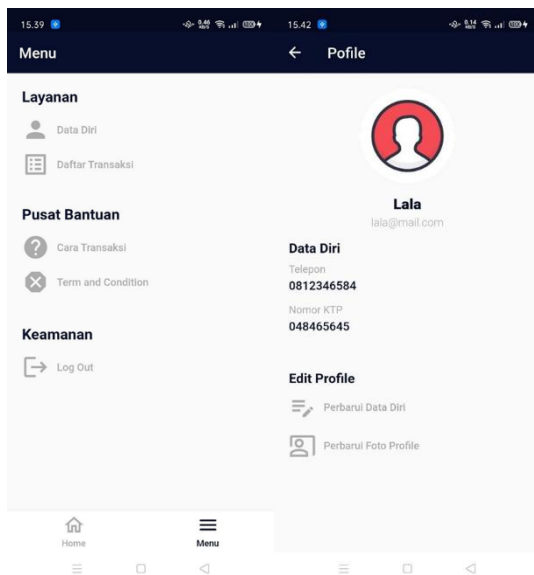

Fig. 24 Menu Page & Profile Page

### 3.3.14 Transaction List Page Display

On this page customers can view transactions that have been made



Fig. 25 Transaction List Page Display

## 3.4 Discussion of Result

System testing is done using the Black Box method. There is a survey that indicates 45% of development cost is spent on software testing [18]. The goal is to test the suitability of the results of making the system against the analysis of the needs that have been made before.

Table 1 Black Box Testing

No	Feature Name	Expected Result	Results that occur	Status
1	Login	Successfully login and proceed to the dashboard page	Successful login and after successful login, proceed to the dashboard page.	Successful
2	Bus Data Input	Bus data input is successful and registered in the bus data table.	The bus data input results are successful and listed in the bus data table.	Successful
3	Route Data Input	Route data input is successful and registered in the route data table.	The route data input results are successful and registered in the route data table.	Successful
4	Schedule Data Input	The schedule data input is successful and listed in the schedule data table.	The schedule data input results are successful and listed in the schedule data table.	Successful
5	Display Transaction Data	Successfully display transaction data and change payment status.	The result of displaying transaction data and changing payment status is successful.	Successful
6	Display User Data	Successfully display user data	The result of displaying user data is successful.	Successful

## 4. CONCLUSION

Based on the implementation and testing in the previous chapters, the following conclusions can be drawn:

1. This system can make mobile-based bus ticket reservations without the need for customers to come directly to the bus agent. Making it easier for customers to get the latest information about ticket prices and departure schedules.
2. This system also provides benefits for agents in promoting the transportation services they offer. In addition, this system also makes it easier for agents to organize schedules.
3. The output of this system can be in the form of pre-sales reports and customer data reports.

## 5. REFERENCES

- [1] N. Shariffudin, M. Azinuddin, N. E. Yahya and M. H. Hanafiah, "Navigating the tourism digital landscape: The interrelationship of online travel sites' affordances, technology readiness, online purchase intentions, trust, and E-loyalty," *Heliyon*, vol. 9, no. 8, pp. 1-14, 2023.
- [2] S. Suginochi, Y. Nii and H. Mizuyama, "Dynamic restaurant reservation method using Scheduling Dutch Auction for addressing social distancing," *Procedia CIRP*, vol. 118, pp. 26-31, 2023.
- [3] T. Silva, R. P. Marques and G. Azevedo, "The Impact of ERP Systems in Internal Auditing: The Portuguese Case," *Procedia Computer Science*, vol. 219, pp. 963-970, 2023.
- [4] S. Zheng and C. Jiang, "Real options in transportation research: A review," *Transport Economics and Management*, vol. 1, pp. 22-31, 2023.
- [5] X. Z, D. Q, M. Y and F. W, "A comparative analysis of major online review platforms: Implications for social media analytics in hospitality and tourism," *Tourism Management*, vol. 58, pp. 51-65, 2017.
- [6] K. Molodetska, S. Veretiuk, M. Gregus, S. Fedushko and Y. Syerov, "Simulating the interaction of social internet services actors using irregular attractors," *Procedia Computer Science*, vol. 198, pp. 688-693, 2022.
- [7] M. Ohyver, J. V. Moniaga and I. Sungkawa, "The Comparison Firebase Realtime Database and MySQL Database Performance using Wilcoxon Signed-Rank Test," *Procedia Computer Science*, vol. 157, pp. 396-405, 2019.
- [8] B. Xin, C. Yan and Y. B. M. Cao, "Facilitating innovation in the API economy: Privacy-enhanced and novelty-aware API recommendation for enterprises," *Journal of Innovation & Knowledge*, vol. 8, no. 3, 2023.
- [9] J. S. Wang, "Reconfigure and evaluate consumer satisfaction for Open API in advancing FinTech," *Journal of King Saud University - Computer and Information Sciences*, vol. 35, no. 9, 2023.
- [10] F. Orejas and S. Perez, "Architectural Connectors for Sequence Diagrams," *Electronic Notes in Theoretical Computer Science*, vol. 206, pp. 111-131, 2008.
- [11] A. Ahonen, M. d. Koning and e. al, "An exploratory study of software engineering in heavy-duty mobile machine automation," *Robotics and Autonomous Systems*, vol. 165, 2023.
- [12] C. Calero, J. Mancebo, F. Garcia and e. al, "5Ws of green and sustainable software," *Tsinghua Science and Technology*, vol. 25, no. 3, 2020.
- [13] A. E. L. Presser, J. M. Young and D. Rosenfeld, "Data collection and analysis for preschoolers: An engaging context for integrating mathematics and computational thinking with digital tools," *Early Childhood Research Quarterly*, vol. 65, pp. 42-56, 2023.
- [14] S. M. Cheema, S. Tariq and I. M. Pires, "A natural language interface for automatic generation of data flow diagram using web extraction techniques," *Journal of King Saud University - Computer and Information Sciences*, vol. 35, no. 2, pp. 626-640, 2023.
- [15] S. Seiferman, R. Heinrich, D. Werle and R. Reussner, "Detecting violations of access control and information flow policies in data flow diagrams," *Journal of Systems and Software*, vol. 184, 2022.
- [16] J. Cohen and J. Gil, "An entity-relationship model of the flow of waste and resources in city-regions: Improving knowledge management for the circular economy," *Resources, Conservation & Recycling Advances*, vol. 12, 2021.
- [17] S. Tummalapalli and V. r. Machavarapu, "Managing Mysql Cluster Data Using Cloudera Impala," *Procedia Computer Science*, vol. 85, pp. 463-474, 2016.
- [18] IPA, "Report of industry actual survey for Embedded Software in 2009," METI, 2009.